



# MASS-STREAM™

Digital Mass Flow Meters and Controllers for Gases



# MASS-STREAM™

## Your best choice for inline flow measurement

### › Introduction

The thermal Bronkhorst® mass flow meters and controllers for gases on the basis of direct through-flow measurement are produced in Germany since 1997. The MASS-STREAM™ series D-6300 works following the constant temperature anemometer principle. Having benefitted from continuous performance enhancements this through-flow technique can be also applied to lower flow ranges, which were previously mainly covered by instruments with by-pass measurement technique.

Our MASS-STREAM™ instruments cover a wide range of measurement and control applications in almost every industry sector - like mechanical engineering and process industry, gas production, food and beverage industry as well as environmental engineering and the chemical industry.

We are committed to a long lasting cooperation with our customers and of course we are also your competent contact for special solutions. You benefit from our well-trained, highly motivated team and our culture of quality. Please visit our website [www.bronkhorst.com](http://www.bronkhorst.com) for the contact data of your local sales partner.

### › Flow ranges

#### Smallest standard range

0,01 ... 0,2 l<sub>v</sub>/min (Air)

#### Highest standard range

200 ... 10.000 l<sub>v</sub>/min (Air)

Within the above mentioned borders intermediate calibrations with a turn-down ratio up to 1:100 are also possible.

In addition Bronkhorst® supplies a wide range of instruments with smaller and higher flow ranges as well as extended standards and tailor-made special solutions.

### › Principle of through-flow measurement

The mass flow meters and controllers consist of a metal body with a straight through-flow path. Two sensors are encased with stainless steel and protrude inside this bore; one is designed as a heater and the other one is designed as a temperature probe. A constant difference in temperature ( $\Delta T$ ) is created between the two sensors. The heater energy required to maintain this  $\Delta T$  is dependent on the mass flow. The working principle is based on King's law of the ratio between the mass flow and the heater energy. That means the higher the flow, the more energy is required to maintain the chosen  $\Delta T$ .

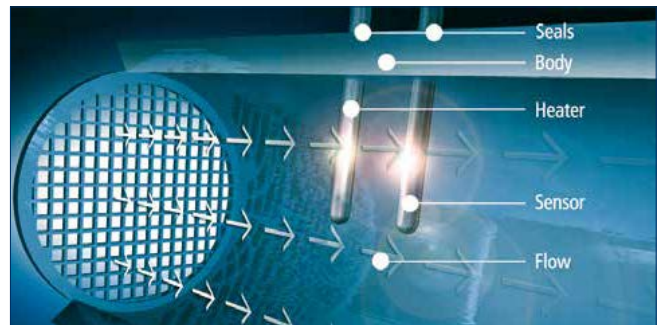

### › Features

- ◆ Direct inline measurement principle
- ◆ Usable for virtually every kind of gas or gas-mix
- ◆ Mass flow measurement and control for a wide scope of applications
- ◆ Digital pc-board with additional fieldbuses for DeviceNet™, PROFIBUS DP, PROFINET, CANopen®, Modbus-RTU and FLOW-BUS
- ◆ Precise control mode and good response times
- ◆ Compact and robust design
- ◆ IP65 for full product range
- ◆ Bodies available in aluminium (AL 50ST/51ST) or stainless steel (SS316) for corrosive gases
- ◆ Sensor made of stainless steel
- ◆ Low sensitivity to dirt and humidity
- ◆ Measurement without moving parts
- ◆ Modern multi-coloured TFT display
  - ◆ IP65 compliant
  - ◆ Operator buttons on the instrument
  - ◆ Customized adjustable multi-functional display: actual flow, totalizer with memory and reset, alarm, setup and much more

### › Applications

- ◆ Aeration
- ◆ Analytical instruments
- ◆ Biogas applications
- ◆ Burner / furnace controls
- ◆ Coating plant and paint-spray lines
- ◆ Exhaust gas and ammonia measurement
- ◆ Gas consumption measurement
- ◆ Gas monitoring systems
- ◆ Gas purging
- ◆ Mechanical engineering
- ◆ N<sub>2</sub>/O<sub>2</sub>-generators
- ◆ Heat treatment and casting
- ◆ and much more

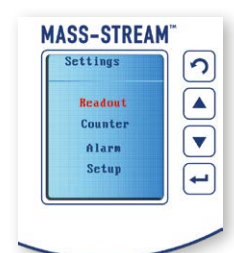

Modern multi-coloured TFT display

# Mass flow meter (MFM) D-63X0

## Mass flow controller (MFC) D-63X1, D-63X3

### › Principle of operation

The digital MASS-STREAM™ mass flow meters and controllers are operated with a main-board with all functions for the flow measurement and control. The instruments can be supplied with commonly used digital or analog input/output signals and when ordering a digital instrument please forward the required presettings. Along with the standard RS232 interface the additional fieldbuses DeviceNet™, PROFIBUS DP, PROFINET, CANopen®, Modbus-RTU and FLOW-BUS are also available. The digital MASS-STREAM™ model series is characterized by a high degree of signal integrity and, as an option, up to 8 calibration curves of different gases and process conditions can be memorized in the instrument. To provide adaptability and flexibility for a wide range of different process conditions our customers are offered the possibility to adjust, to optimize and to evaluate the parameters and control characteristics, even whilst on site.

The accompanying software is a basic part of our scope of supply of digital mass flow meters and controllers, as well as the calibration certificate, the 8-pin DIN connector for the electrical connection and the software and documentation on CD. The MASS-STREAM™ mass flow controllers are delivered as compact control units up to flows of 1.000 l<sub>v</sub>/min Air-equivalent, with the modular constructed solenoid valve integrated onto the body. Higher gas flows > 1.000 l<sub>v</sub>/min Air-equivalent are controlled with mechanically connected separate valves and K<sub>v</sub>-values up to 8,2. (Additional special valves and combinations on request.)

### › D-6300 dimensions (in mm)

Model	A	B	C	D	E	F	G	H	I
D-6310	95	G¼"	G¼"	34	15	117	95		
D-6320	95	G¼"	G¼"	34	15	117	95		
D-6340	95	G¼"	G¼"	34	15	114	95		
D-6360(A)	95	G½"	G½"	34	16	122	95		
D-6370	117	G½"	G½"	58	25	136	95		
D-6370A	150	G½"	G½"	74	33,5	155	95		
D-6380	143	G1"	G1"	83	37,5	164	95		
D-6390	211	G2"	G2"	120	56,3	201	95		
D-6311	95	G¼"	G¼"	34	15	117	95		
D-6321	95	G¼"	G¼"	34	15	117	95		
D-6341	95	G¼"	G¼"	34	15	114	95		
D-6361/FAS	110	G½"	G½"	34	16	122	95		
D-6361(A)/002BI	145	G½"	G½"	34	16	122	95	-	106
D-6371A/003AI	208	G½"	G½"	74	33,5	155	95	-	130
D-6371/004BI	192	G½"	G½"	65	25	136	95	10	186
D-6381/003AI	212	G1"	G½"	83	37,5	164	95	-	134
D-6381/003BI	236	G1"	G1"	89	42	168	95	-	147
D-6391/003BI	304	G2"	G1"	120	56,3	201	95	-	161

Dimensions for other models, please consult our website.

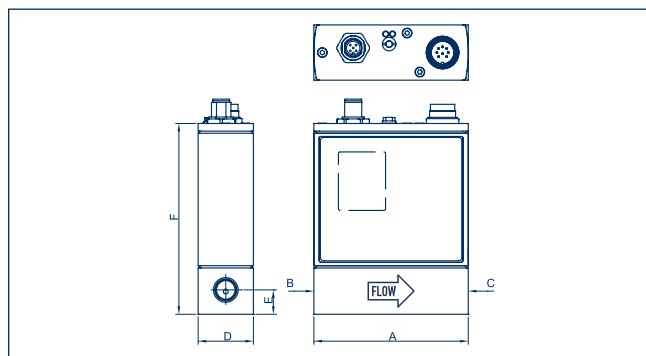

Model D-6310, D-6311, D-6320, D-6321, D-6340, D-6341, D-6360(A), D-6361/FAS

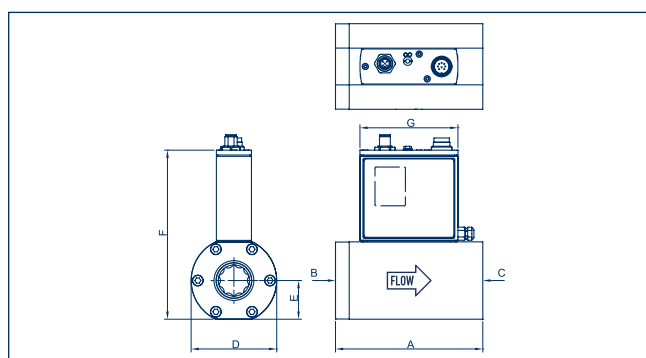

Model D-6370(A), D-6380, D-6390

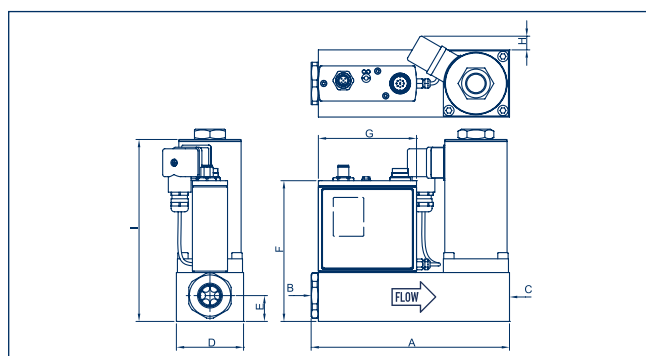

Model D-6361(A)/002BI, D-6371/004BI

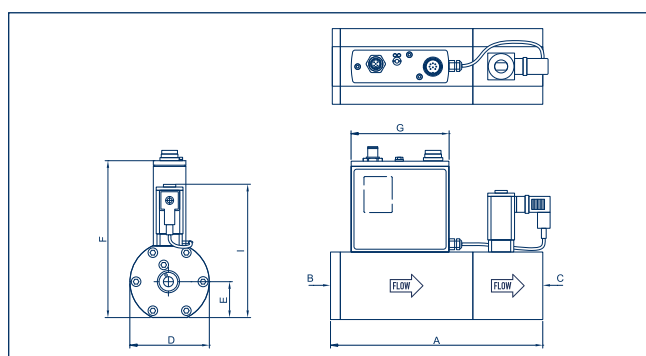

Model D-6371A/003AI, D-6381/003AI, D-6381/003BI, D-6391/003BI

## › Standard measurement ranges

Mass flow meter/controller Model	Flow ranges (Air) intermediate ranges are available
D-6310 - Hxx - BB - xx - 99 - x - S - Dx	Min. 0,01...0,2 l <sub>r</sub> /min Max. 0,1...2,0 l <sub>r</sub> /min
D-6320 - Hxx - BB - xx - 99 - x - S - Dx	Min. 0,05...1,0 l <sub>r</sub> /min Max. 0,35...7,0 l <sub>r</sub> /min
D-6340 - Hxx - BB - xx - 99 - x - S - Dx	Min. 0,14...7,0 l <sub>r</sub> /min Max. 0,5...50,0 l <sub>r</sub> /min
D-6360 - Hxx - CC - xx - 99 - x - S - Dx	Min. 0,4...20,0 l <sub>r</sub> /min Max. 2,0...200 l <sub>r</sub> /min
D-6360A - Hxx - CC - xx - 99 - x - S - Dx	Min. 1...50 l <sub>r</sub> /min Max. 5,0...500 l <sub>r</sub> /min
D-6370 - Hxx - CC - xx - 99 - x - S - Dx	Min. 2,0...100 l <sub>r</sub> /min Max. 10,0...1.000 l <sub>r</sub> /min
D-6370A - Hxx - CC - xx - 99 - x - S - Dx	Min. 4,0...200 l <sub>r</sub> /min Max. 20,0...2.000 l <sub>r</sub> /min*
D-6380 - Hxx - DD - xx - 99 - x - S - Dx	Min. 10,0...500 l <sub>r</sub> /min Max. 50,0...5.000 l <sub>r</sub> /min
D-6390 - Hxx - FF - xx - 99 - x - S - Dx	Min. 40,0...2.000 l <sub>r</sub> /min Max. 100...10.000 l <sub>r</sub> /min
D-6311 - Fxx - BB - xx - 99 - x - S - Dx	Min. 0,01...0,2 l <sub>r</sub> /min Max. 0,1...2,0 l <sub>r</sub> /min
D-6321 - Fxx - BB - xx - 99 - x - S - Dx	Min. 0,05...1,0 l <sub>r</sub> /min Max. 0,35...7,0 l <sub>r</sub> /min
D-6341 - Fxx - BB - xx - 99 - x - S - Dx	Min. 0,14...7,0 l <sub>r</sub> /min Max. 1,0...50,0 l <sub>r</sub> /min
D-6361/ D-6363 - Fxx - CC - xx - 99 - x - S - Dx	Min. 0,4...20,0 l <sub>r</sub> /min Max. 4,0...200 l <sub>r</sub> /min
D-6361A - Fxx - CC - xx - 99 - x - S - Dx	Min. 1,0...50 l <sub>r</sub> /min Max. 10...500 l <sub>r</sub> /min
D-6371/ D-6373 - Fxx - CC - xx - 99 - x - S - Dx	Min. 2,0...100 l <sub>r</sub> /min Max. 20,0...1.000 l <sub>r</sub> /min
D-6371A - Fxx - CC - xx - 99 - x - S - Dx	Min. 4,0...200 l <sub>r</sub> /min Max. 40,0...2.000 l <sub>r</sub> /min*
D-6381/ D-6383 - Fxx - DD - xx - 99 - x - S - Dx	Min. 10,0...500 l <sub>r</sub> /min Max. 100...5.000 l <sub>r</sub> /min
D-6391 - Fxx - FD - xx - 99 - x - S - Dx	Min. 40,0...2.000 l <sub>r</sub> /min Max. 200...10.000 l <sub>r</sub> /min

\* up to 2.500 l<sub>r</sub>/min on request.

Technical changes and alterations in construction are reserved.

## › Conversion factor

MASS-STREAM™ mass flow meters and controllers are basically calibrated on Air. If other gases or gas mixtures are used a conversion factor CF will be applied. This factor is determined by applying a complex formula\*.

For a number of commonly used gases you will find the value in the adjoining chart.

\*The instrument is always calibrated to the customer specific needs, benefitting from more than 25 years experience.

## › Conversion factors (I<sub>n</sub> ± 1013 mbar and 0 °C Air temperature)

Gas	CF D-631x and D-632x	CF D-634x up to D-639x	Gas	CF D-631x and D-632x	CF D-634x up to D-639x
Air	1,00	1,00	CO <sub>2</sub>	0,86	1,13
Ar	1,50	2,02	HCl	1,12	1,53
CH <sub>4</sub>	0,77	0,61	N <sub>2</sub>	1,00	1,00
C <sub>2</sub> H <sub>2</sub>	0,66	0,68	NH <sub>3</sub>	0,82	0,74
C <sub>2</sub> H <sub>4</sub>	0,70	0,75	NO	1,00	1,01
C <sub>2</sub> H <sub>6</sub>	0,58	0,62	N <sub>2</sub> O	0,83	1,08
C <sub>3</sub> H <sub>8</sub>	0,43	0,51	O <sub>2</sub>	0,99	0,97
C <sub>4</sub> H <sub>10</sub>	0,32	0,41	Xe	1,96	6,09
CO	1,01	1,04	Other gases on request.		

Please refer to [www.fluidat.com](http://www.fluidat.com)

The mentioned values are only regarded as an indication. The exact conversion factors are significantly dependent on the process parameters, like media temperature and operating pressure, and on the physical characteristics of the gas. The best accuracy can be obtained by calibrating the instrument under operating conditions. The conversion factor causes an additional error in the absolute accuracy. With a conversion factor >1 this error is 2 x CF (in % FS) and with a conversion factor <1 this error is 2 / CF (in % FS).

## › Flow profile and sensitivity

In general mass flow measurement is very sensitive to variations of the shape of the flow profile. The MASS-STREAM™ instruments are designed for a consistent, fully developed flow profile in the metering section. Installing a suitable well-sized inlet pipe is recommended for our robust and concurrent precise mass flow measurement. Without an inlet run or insufficient inlet piping conditions severe deviations in the accuracy could possibly occur.

## › Pressure loss

The pressure drop over the instrument's D-6300 measurement chamber is almost comparable to a straight run of pipe of the same diameter and is thus almost negligible.

However, to make the instruments less sensitive to upstream piping configurations (e.g. turbulences, welded joints, elbows) special mesh screens are required to condition the flow profile. These meshes create a certain pressure drop.

The frequently used compression fittings can cause a considerable additional pressure loss. We recommend to install fittings with maximized internal diameter. We would be happy to advise you on questions about the suitable inlet pipe in front of the instrument.

## › Enquiry and order information

In order to supply the correct instrument for your application, please submit the following data:

- ◆ Type of gas
- ◆ Flow range
- ◆ Operating temperature
- ◆ Operating pressure (for controllers inlet and back pressure)
- ◆ Electrical connection
- ◆ Desired output signal
- ◆ Type of fittings (only when needed)
- ◆ Analog or digital presettings



## » Technical specifications

### Measurement system

Accuracy (at calibration conditions)	$\pm 1,0\%$ RD plus $\pm 0,5\%$ FS
Repeatability	$< \pm 0,2\%$ FS
Pressure sensitivity	$\pm 0,3\%$ RD / bar typical (Air)
Temperature sensitivity	$\pm 0,2\%$ RD / °C (Air)
Attitude sensitivity	at 90° deviation from horizontal max. error 0,2 % at 1 bar typical N <sub>2</sub>
Control stability	$< 0,2\%$ FS typical
External leak integrity	$< 2 \times 10^{-8}$ mbar l/s He
Response time sensor (63 %)	D-631x / D-632x: approx. 0,3 seconds other models: approx. 0,9 seconds
Settling time (controller)	up to approx. 2 seconds (depending on selected valve)
RFI (radio frequency interference)	according to EU declaration

### Mechanical parts

Sensor	Stainless steel SS 316 (AISI 316L)
Instrument body	Aluminium AL 505T/515T (anodised) or stainless steel SS 316
Sieves and rings	Stainless steel SS 316
Protection	IP65 (with and without display)

### Operating limits

Measuring range (turn-down-ratio)	up to 1...100 % (1:100) for meters up to 2...100 % (1:50) for controllers
Type of gases	almost all gases and gas-mixes, compatible with chosen materials
Temperature	0...50 °C
Pressure rating	0...10 bar (g) for instrument body in aluminium, 0...20 bar (g) for instruments body in stainless steel SS 316, 0...30 bar (g) on request
Warm-up time	30 minutes for optimum accuracy within 30 seconds for accuracy $\pm 4\%$ FS

### Electrical properties

Supply voltage	+15...24 Vdc $\pm 10\%$
Current peak values	Meter approx. 75 mA at 0 % flow approx. 125 mA at 100 % flow Controller add 250 mA add 30 mA for display, if applicable add 50 mA for additional fieldbus, if applicable
Output signal	0...10 Vdc / 0...5 Vdc active or 0...20 mA / 4...20 mA active
Connector	8-pin round DIN (male) for analog and RS232 additional connectors for the fieldbus: ◆ 5-pin M12 (male) for DeviceNet™ FLOW-BUS Modbus-RTU PROFINET CANopen® ◆ 5-pin M12 (female) for PROFIBUS-DP

Technical changes and alterations in construction are reserved.



## Model number identification

